



**ULTRA HEAT / ULTRA COOL**  
**SUPERIOR PERFORMANCE IN EXTREME TEMPERATURES**

**12000 BTU / H WALL MOUNTED HEAT- PUMP SYSTEM**

**SUBMITTAL DATA: TW12HQ3D6D**

Job Name	Location	Date
Purchaser	Engineer	
Submitted To	For	<input type="checkbox"/> Reference <input type="checkbox"/> Approval <input type="checkbox"/> Construction
Unit Designation	Schedule No.	

**AHRI CERTIFIED REF  
NO: 10062019**



Sold Separately

YAG1FB2F (Included, ONLY ONE)

**GENERAL FEATURES**

- Variable Speed (Inverter) Two-Stage Compressor
- Low Ambient Heating ( down to -22° F)
- High Ambient Cooling ( up to - 129° F)
- WIFI Included
- Wireless Remote with LCD Display (included)
- Wired Controller (Sold Separately) XE71
- 7 Indoor Fan Speeds /4 Way Airflow Operation
- Copper Tube/Aluminum Fins w/Acrylic Resin Anti-Corrosion both inside and out
- I-FEEL Function



SYSTEM RATINGS		INDOOR UNIT DATA		
<b>Cooling</b>		<b>Fan Motor</b>		
Rated Capacity	12,000 BTU/H	Type	Cross-flow	
Capacity Range	2,900 - 15,354 BTU/H	Output Power	60W	
Power Input	784 W	FLA	0.09A	
Power Input (Min/Max)	75/1500 W	<b>Air flow</b>	(Low/High) 235/500 CFM	
SEER	30.5	<b>Air Throw</b>	(Max) 29.5 ft	
EER	15.3	<b>Sound Level</b>		
<b>Heating at 47° F</b>		Cooling (Low/High)	22/49 dB(A)	
Rated Capacity	12,200 BTU/H	Heating (Low/High)	22/49 dB(A)	
Capacity Range	3,071 - 18,766 BTU/H	<b>Dehumidification</b>	3.0 pt/hr	
Power Input	940 W	<b>OUTDOOR UNIT DATA</b>		
Power Input (Min/Max)	250/1600W	<b>Compressor</b>		
HSPF	14.0	Type	DC Inverter Driven 2-Stage Rotary	
COP	3.8	RLA	6.9 A	
<b>Heating at 17° F</b>		<b>Fan Motor</b>		
Rated Capacity	8,100 BTU/H	Output Power	30 W	
<b>Operating Range</b>		RLA	0.24 A	
Cooling	(Max)	129°F (54°C)	<b>Sound Level</b>	53 dB(A)
	(Min)	0°F (-18°C)	<b>Refrigerant Piping Data</b>	
Heating	(Max)	75°F (24°C)	Liquid Pipe Size (OD)	1/4-in
	(Min)	-22°F (-30°C)	Gas Pipe Size (OD)	1/2-in
<b>Power Supply</b>		Connection Method	Flared	
Normal Operational Voltage	208/230 V, 1 Phase, 60 Hz	Factory Charge	R410A/49.4 oz	
Voltage Range	187 - 253 V	Additional Charge	0.2 oz/ft	
Main Power Wire Size	12-2 AWG	Pre-Charge Length	25-ft	
Interconnecting Cable Wire Size	14-4 AWG	MAX Refrigerant Pipe Length	98-ft	
MCA	9 A	MIN Refrigerant Pipe Length	10-ft	
MOCP/Breaker Size	15 A	MAX Refrigerant Pipe Elevation	49-ft	





## FEATURES & FUNCTION SUMMARY: TW12HQ3D6D

SYSTEM FEATURES	
Inverter Type	G10
Ultra Low Frequency Torque Control	Yes
Power Factor Correction	Yes
Compressor Type	High Eff. Two Stage Rotary
Refrigerant Type	R410A
Basepan With Electric Heater	YES
Compressor With Electric Heater	YES
Indoor & Outdoor Fin Coating	Acrylic Resin/Anti-Corrosion
Intelligent Defrosting	YES
Intelligent Preheating	YES
Low Voltage Startup	YES
Memory/Power Failure Recovery	YES
Self Diagnosis	YES
Wired Controller Interface	NO
WIFI Included	YES
Indoor Fan Type	Crossflow
Multi Fan Speeds	7 Speeds
Indoor Unit Display	YES
Auxiliary Electrical Heater	NO
Ventilation (Outdoor Air)	NO
REMOTE CONTROLLER FUNCTIONS	
Auto Mode	YES
Auto Fan	YES
Auto Swing (Horizontal Auto Swing)	YES
Auto Swing - 180°(Vertical Auto Swing)	YES
Clock on Remote Controller	YES
Dry Mode	YES
Dry Anti-Mildew (X-Fan) Mode	YES
Energy Saving Mode	NO
Dirty Filter Alert	NO
Fan Speed Control (7 speeds)	YES
I Feel Function	YES
Privacy Lock on Remote Controller	YES
Quiet Mode	YES
Room Temperature Display	NO
Sleep Mode	YES
4 Sleep Modes Options	YES
Timer Mode	YES
Turbo Mode	YES
Display On/Off Control	YES
Freeze Guard Mode	YES
Power Failure Mode	YES



**EXTENDED RATINGS: TW12HQ3D6D**

**ULTRA COOL**

**ULTRA HEAT**

COOLING PERFORMANCE							HEATING PERFORMANCE				
Outdoor Ambient Temperature (DB)	Return Air Temperature					Outdoor Ambient Temperature (DB)	Return Air Temperature				
	80° F (DB)						70° F (DB)				
	TC (Btu/h)	SHR	EER	Power Input (W)	SHR %		TC (Btu/h)	COP	Power Input (W)		
<b>MAX OUTPUT</b>	0°F	7000	5075	3.22	637	73%	<b>MAX OUTPUT</b>	-22°F	7137	1.37	1523
	5°F	7280	5314	3.28	650	73%		-20°F	7549	1.43	1544
	10°F	7490	5487	3.28	670	73%		-15°F	7967	1.49	1566
	15°F	7700	5660	3.28	689	74%		-10°F	8502	1.57	1588
	20°F	8050	5938	3.30	715	74%		-5°F	9011	1.64	1610
	25°F	8400	6216	3.32	741	74%		0°F	10400	1.86	1639
	30°F	8680	6446	3.35	761	74%		5°F	12000	2.11	1668
	35°F	8960	6675	3.37	780	75%		10°F	12800	2.33	1610
	40°F	9800	7350	3.40	845	75%		15°F	13520	2.48	1602
	45°F	10220	7692	3.28	917	75%		17°F	14240	2.62	1595
	50°F	10640	8033	3.16	988	76%		20°F	14400	2.77	1523
	55°F	11340	8618	3.20	1040	76%		25°F	14560	2.89	1479
	60°F	12110	9236	3.22	1105	76%		30°F	14880	2.98	1465
	65°F	12880	9853	3.23	1170	77%		35°F	15040	3.09	1428
	70°F	13510	10371	3.30	1203	77%		40°F	15200	3.20	1392
	75°F	14140	10888	3.36	1235	77%		45°F	15680	3.23	1421
	80°F	14700	11357	3.44	1255	77%		47°F	16000	3.23	1450
	85°F	15260	11827	3.51	1274	78%		50°F	16640	3.31	1472
	90°F	14630	11373	3.34	1287	78%		55°F	17280	3.39	1494
	95°F	14000	10920	3.16	1300	78%		60°F	18400	3.51	1537
	100°F	13300	10406	2.90	1352	78%		65°F	17600	3.26	1581
105°F	12600	9891	2.63	1404	79%	70°F	16960	3.12	1595		
110°F	12180	9591	2.47	1450	79%	75°F	15840	2.88	1610		
115°F	11760	9290	2.31	1495	79%						
120°F	10360	8236	2.01	1508	80%						
125°F	9380	7478	1.82	1515	80%						
129°F	8400	6720	1.62	1521	80%						

<b>LEGEND:</b>	<b>W - Watts</b>
	<b>DB - Dry Bulb</b>
	<b>TC - Total Capacity</b>
	<b>SHR - Sensible Heat Ratio</b>
	<b>COP - Coefficient of Performance</b>





## DIMENSIONAL SPECIFICATIONS: TW12HQ3D6D

### MINIMUM SPACING REQUIREMENTS

#### INDOOR

Units: inch (mm)

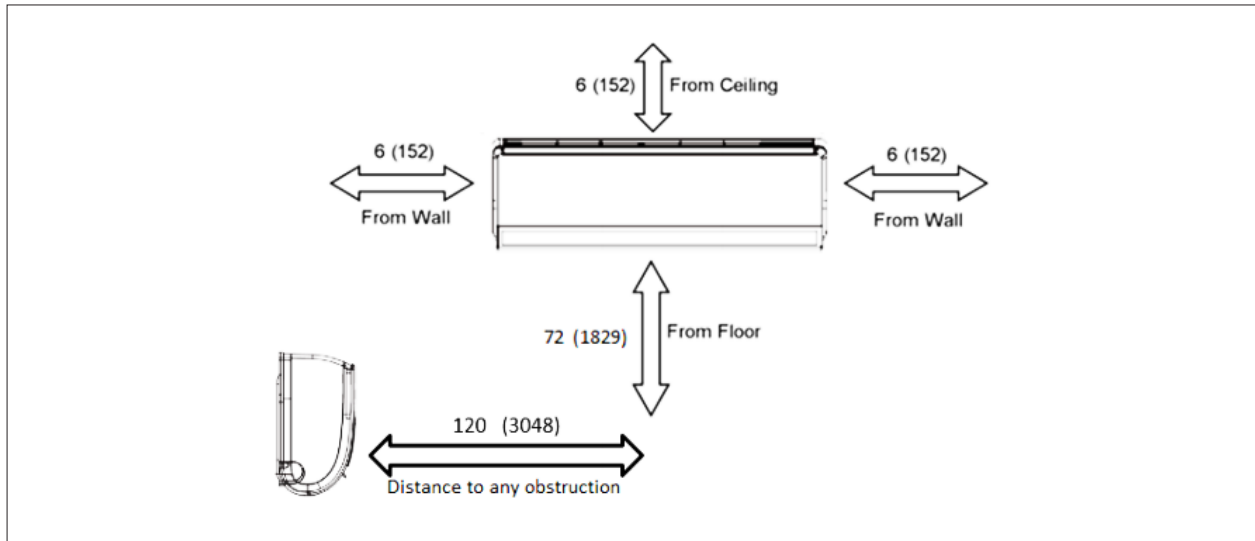

### MINIMUM OUTDOOR CLEARANCE

Units: inch (mm)

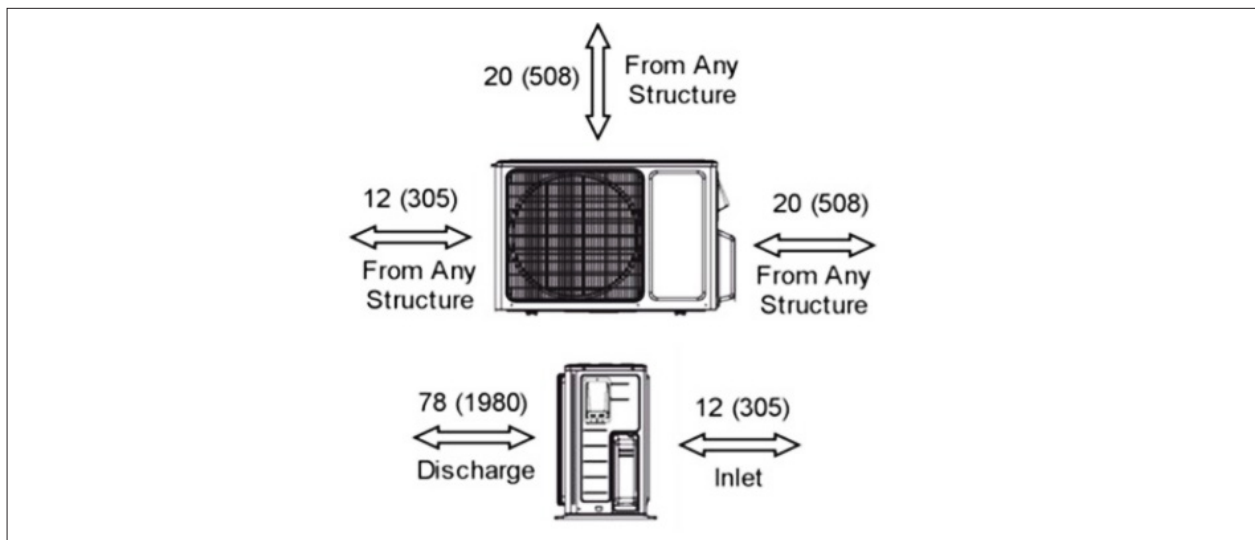



## DIMENSIONAL SPECIFICATIONS: TW12HQ3D6D

### INDOOR UNIT DIMENSIONS

Model No: TW12HQ3D6DI

Units: inch

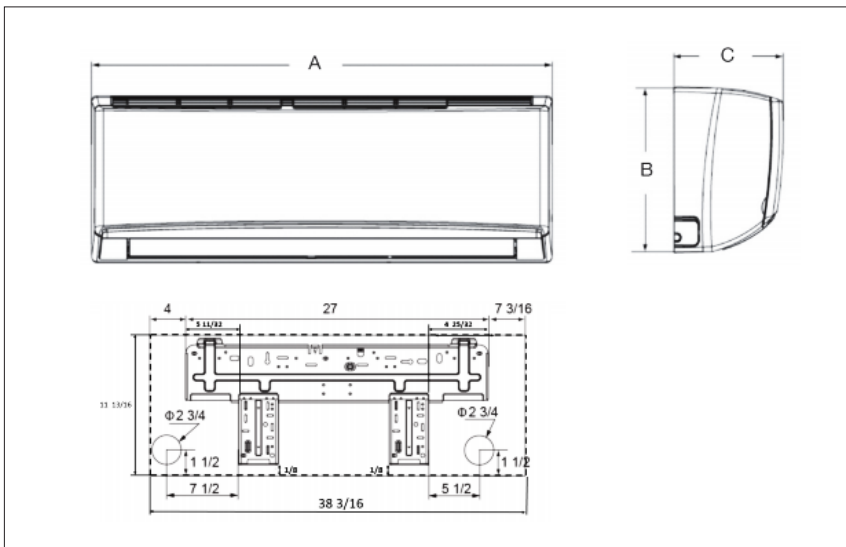

Dimensions	
A	39 1/2
B	12
C	8 7/8

**Weight (Net/Shipping) 29 / 36 LBS**

Liquid Line Valve	1/4-in OD Flared
Gas Line Valve	1/2-in OD Flared
Drain Connector	5/8-in OD

### OUTDOOR UNIT DIMENSIONS

Model No: TW12HQ3D6DO

Units: inch

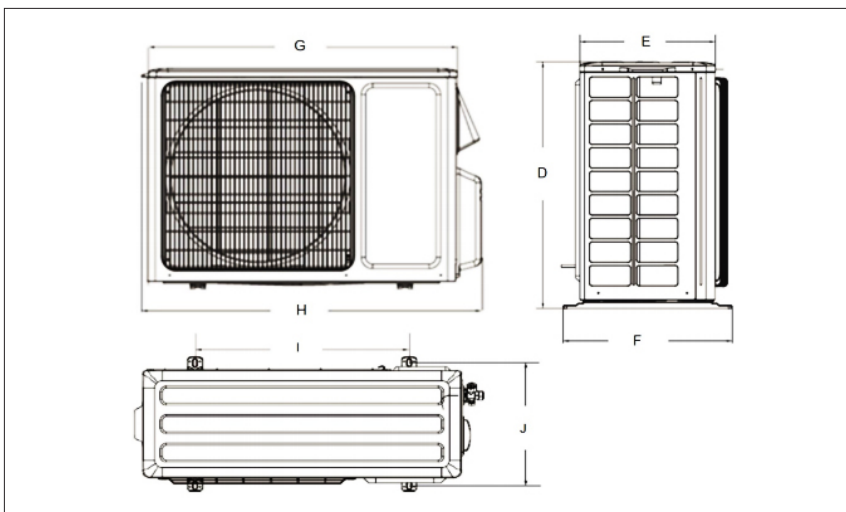

Dimensions	
D	23 1/2
E	12
F	14 7/8
G	33 1/4
H	34 5/8
I	19 3/8
J	13 1/2

**Weight (Net/Shipping) 98 /104 LBS**

Liquid Line Valve	1/4-in OD Flared
Gas Line Valve	1/2-in OD Flared

**Notes:**

1. Recommended Interconnecting Cable Type 14 AWG 4 Stranded Copper Conductors Wire.
2. Power wiring cable size must comply with applicable national and local codes.
3. Test conditions are based on AHRI 210/240.